



The DAF LF Series



Dedicated to distribution







The DAF LF Series

Designed to deliver

Elected 'International Truck of the Year' in 2002, the DAF LF Series has been a winner right from the start. With its modern and spacious cab design, low chassis weight for the highest payloads in its class, tight turning circle for maximum manoeuvrability, easy cab access and car-like driving characteristics, the DAF LF Series is the ideal partner for city and regional distribution. More powerful engines, optional AS-Tronic automated gearbox, a mildly restyled exterior and upgraded interior design, make the LF Series even more attractive than its award-winning predecessor. The LF Series, designed to deliver.





At home in town and country

The perfect partner for distribution

DAF's LF Series offers superb manoeuvrability, easy cab access, low kerb weights for class-leading payloads, comfort, performance and fuel efficiency. The ideal distribution truck, with GVWs from 6 to 21 tonnes. Smooth and comfortable for the driver. Reliable, flexible and economical for the operator. Furthermore, the modern design of the LF reflects your company's image. The DAF LF Series is not only ideally suited to town and country, it will also meet the needs of longer trips.

The subtle exterior redesign gives the LF a more sturdy appearance. The more pronounced upper and lower grille with aluminium strip to signify compliance with the Euro 4 and Euro 5 emission standard, the larger mirrors for a larger field of vision, and the cat's-eye combi-lights, all give the LF a more modern look, without immediately outdating the previous model.

Inviting interior

Open the door and you immediately experience the quality of the LF interior. Indeed, the styling and standard of finish more resemble that of a luxury passenger car. The colour schemes and materials used mean that the LF cab offers a pleasant, comfortable working environment. The dashboard and modern instrument panel, the adjustable steering wheel with integrated controls and optional airbag, and the well positioned handles and switches, all demonstrate how the creation of an ergonomic working environment was a key target in the design process of the LF Series.

Powerful engines

The four- and six-cylinder PACCAR engines feature a larger swept volume giving up to 20% higher torque and power output. Remarkably for all

engine ratings, maximum torque is available over a wide rev range, resulting in better performance, greater flexibility and less gear-shifting. Additionally the engines are more fuel efficient, saving up to 4% on fuel consumption. The LF Series offers power ratings from 140 to 285 hp and all engines comply with Euro 4 and Euro 5 emission standards without the need for a particulate filter, thanks to the high pressure common rail injection system and SCR after-treatment technology.

AS-Tronic automated gearbox

For the LF Series the AS-Tronic gearbox is an option on all vehicle types. This automated six-speed gearbox employs an electronic system to select the right gear for every situation, resulting in better fuel efficiency and enhanced driver comfort. And as the driver can fully concentrate on traffic conditions, the AS-Tronic gearbox can improve safety too. 'Two pedal' driving that makes the ideal distribution truck even easier to operate.

Superb manoeuvrability, easy cab access, low kerb weights for class-leading payloads, comfort, performance and great fuel efficiency.



*A restyled exterior with ample mirrors,
providing a larger field of vision
for extra safety.*





Modern, distinctive and fit for purpose

Dedicated to productivity

Trucks like the DAF LF Series are used in many different applications, from urban and regional distribution to long distance lightweight transport and special applications such as roadsweepers, refuse collectors or fire engines. This versatility requires an extensive vehicle range to achieve greater productivity in every transport application.

Productivity starts with the right choice of specifications. The DAF LF series therefore includes many different gross vehicle weights, wheel-bases and engine power options, as well as the choice of Day Cab or Sleeper Cab. The LF45 is available in GVWs of between 6 and 12 tonnes, whereas the LF55 covers GVWs from 12 up to 21 tonnes, while offering a maximum train weight of up to 32 tonnes. In all versions, the low kerb weight ensures best-in-class payload for the highest productivity.

Compact yet spacious

Both the Day Cab and the Sleeper Cab combine compact external dimensions for maximum manoeuvrability and loadspace with a surprisingly spacious interior. The easy access, excellent visibility and ergonomic controls are evidence that the driver has been the focus of attention in the development of the LF. The wide, deep windscreen and narrow pillars provide excellent visibility, while green-tinted glass helps keep the cab cool. The four mirror layout provides a larger field of vision for greater safety. The LF has four-point cab

mountings to maximize comfort. Noise levels are low, resulting in less driver fatigue and more safety.

Stylish and functional

The modern exterior design of the LF is certainly important; the truck is the operator's business card on the road. But for every DAF truck however, functionality has been an even more important development driver. The durable steel bumper – a trusted DAF feature – is only one example of this design philosophy, as are the virtually unbreakable Lexan covers on the high-intensity headlamps and the optional cat's eye combi-lights, which all help to minimize minor accident damage. The corner spoilers, integrated in the design, help minimize road spray fouling the door handles, side mirrors and windscreen. Aerodynamic options such as the roof spoilers and top/side collars improve fuel economy. For additional comfort an integral designed external sun visor is also available.



Modern design and functionality go hand in hand in the DAF LF Series.



An invitingly spacious interior.

The bunk in the Sleeper Cab features a full-size mattress of 2 m long, 70 cm wide and 12 cm thick.



The tachograph is practically positioned in the header shelf.

An interior that suits every driver

A great place to work

The LF's interior is designed around the driver's needs. With fully adjustable seats, controls logically grouped around the driving position, and a dashboard that would look at home in a luxury passenger vehicle, it is an ergonomic place to work.



Trucks designed for local and regional distribution and urban deliveries frequently stop and start for loading and unloading. Such operation demands easy entry and exit, so the LF has a large illuminated entry step and a door that opens to a full 90°. Good cross-cab access allows the driver to easily get out on the co-driver's side, an important feature in inner-city distribution.

Extra driver comfort

The LF cab interior has a sense of space and light. The high-backed driver's seat is fully adjustable and available with air suspension for optimum comfort. A co-driver seat is standard, but a dual passenger seat is available too, for three man seating.

Special attention has been given to the interior colours and trim, with less frequently used areas in light, warm shades, and intensively used areas in darker, easier to clean colours. As a result, the LF cab will still look good after many years of intensive use, good for resale values. What else do

drivers value? The many storage areas for delivery notes, writing materials, road maps etc.

A place for everything

Storage facilities are class leading, with compartments that provide ample room to carry items. There is space for maps and papers in the door panels, central cup holders, flat over-dashboard storage and two compartments in the header shelf complete with nets. A cargo net is also located on the back wall. The Sleeper Cab has three additional storage units beneath the bed. The header shelf also accommodates the tachograph, easily within reach.

Comfort at night

At night, the interior lighting provides even distribution throughout the cab. There are two surface-mounted lights in the Day Cab roof, and four in the Sleeper Cab. The bunk in the Sleeper Cab features a full-size mattress of 2 m long, 70 cm wide (60 cm behind the seats) and 12 cm thick, as well as blackout curtains.

The AS-Tronic control panel is located on the console next to the driver's seat.



A comfortable, inviting and functional interior that uses available space to the maximum.



Comfort and convenience in a safer environment

Uncompromised ergonomic design



From the logical grouping of switches on the dashboard to the backlit controls on the steering wheel and driver's door console, it is clear that safety and ease of operation were given the highest priority in the design of the LF Series.

The thick-rimmed, four-spoke steering wheel is comfortable and gives unhindered view of the instruments. The steering wheel is generously adjustable in rake and angle and incorporates an optional airbag and illuminated switches for cruise control, exhaust brake and adjustable speed limiter. Additional switches for a hands-free telephone can also be specified. The steering wheel, however, is

only the first touch of quality when driving the LF.

Well-thought-out

The cockpit-shaped dashboard is well-thought-out and has all controls easily within reach in logical positions. Where fitted, the AS-Tronic control panel is conveniently located on a console next to the driver's seat. All handles and controls are there where you expect them. One of DAF's main objectives in the design of the LF was that its controls should be intuitive. Just get in and drive!

Information on request

The modern instrument panel with purpose-designed layout has stylish aluminium highlights. Offering excellent clarity with minimal reflection,

the main gauges provide information on primary functions. The central information display presents only essential vehicle information when needed or at the driver's request. This ensures that the driver is not unnecessarily distracted but still receives any relevant information. The LCD information display also provides information on trip duration, fuel consumption, average speed and PTO hours.

Heating and ventilation

The LF Series is equipped with a generously dimensioned heating and ventilation system. On distribution trucks this is an important feature as the doors are continually being opened and closed. In winter, a lot of the heat escapes and the interior needs to be restored to a comfortable temperature as quickly as possible. A lot of attention has of course been devoted to the demisting of the front windscreen and side windows to guarantee unrestricted visibility at all times. Air conditioning is available on all models, as is a night heater for the Sleeper Cab.



Optional dash-mounted position for mobile phone, pre-wired for 'hands free' connection with most GSM phones and steering wheel controls.

One of DAF's main objectives in the design of the LF was that its controls should be intuitive. Just get in and drive!



Four- and six-cylinder engines

The comfort of power

The LF Series is equipped with four- and six-cylinder PACCAR engines, developed to meet the latest Euro 4 and Euro 5 emission standards. Larger displacement in all versions result in up to 20% more power and torque, whilst fuel consumption is reduced. The 4.5 and 6.7 litre engines are designed to offer high levels of efficiency, reliability and durability to the operator and smooth, comfortable power to the driver.

Building on the reputation for reliability, performance and fuel economy of the PACCAR Euro 3 engines, the Euro 4 and Euro 5 engines have a larger displacement for even better performance and durability. Both the modern four- and six-cylinder engines in the DAF LF are characterized by electronically controlled high pressure common rail diesel injection in combination with SCR technology, satisfying the Euro 4 and Euro 5 emission requirements without the need of a particulate filter.

140 to 285 efficient horses

The LF Series offers a wide choice of power ratings to suit every application in the most efficient way. The 4.5 litre four cylinder PACCAR FR engine is available with outputs of 140 hp, 160 hp or 185 hp and torque levels of 550 Nm, 600 Nm and 700 Nm respectively. The 6.7 litre six cylinder PACCAR GR engine offers maximum outputs of 220 hp, 250 hp or 285 hp with corresponding torque figures of 850 Nm, 950 Nm, or 1,020 Nm. Importantly, the maximum available torque is available from as low as 1,200 rpm, resulting in greater flexibility and less gear shifting.

Powerful benefits for operators

Lower operational costs, and enhanced vehicle availability and durability were important development drivers for the LF Series. The PACCAR

The 6.7 litre six cylinder PACCAR GR engine offers maximum outputs from 220 hp to 285 hp.



The 4.5 litre four cylinder PACCAR FR engine is available with outputs from 140 hp to 185 hp.

engines in the LF Series not only offer better performance, they also offer larger service intervals of up to 55,000 km depending on vehicle type and type of operation.

The standard exhaust brake and cruise control, are actuated by the steering wheel switches, offering increased braking performance and relaxed driving, contributing to driver comfort and lowering operating cost.

The PACCAR Euro 4 and Euro 5 engines for the LF45 and LF55 provide higher outputs and greater torque, whilst reducing fuel consumption.

The clean route



The compact lay out of the DAF SCR installation leaves enough free space on the chassis for large fuel tanks and other equipment.

The AdBlue tank has a standard capacity of 26 litres. This means that you do not have to fill the AdBlue tank more often than the diesel tank.



DAF SCR Technology
for a bright future



All PACCAR engines in the LF Series feature Selective Catalytic Reduction (SCR) technology to meet the Euro 4 and Euro 5 emission standards. SCR technology is simple, reliable and efficient. DAF SCR Technology, the clean route to a bright future.

As SCR is an after-treatment system, it allows the most efficient combustion in the engine. And DAF goes even further. DAF SCR Technology comes with a whole range of PACCAR engines with state-of-the-art high pressure injection technology that makes a particulate filter unnecessary. With optimized combustion for class-leading fuel efficiency, performance, durability and reliability. The ideal foundation for low cost of operation and high resale values.

How does it work?

It's simple and effective. Basically the exhaust gas after-treatment system consists of a catalytic converter, a dosing unit and an AdBlue tank with at least enough capacity to match the range offered by the fuel tank. The exhaust gases are led through the Selective

Catalytic Converter, where AdBlue is injected. A chemical process takes place, resulting in NOx emissions being broken down into harmless water vapour and nitrogen. AdBlue consumption is only 3 % of the diesel consumption, or for an LF only 0.5 litre per 100 kilometres. The AdBlue tank on the LF has a capacity of 26 litres, ensuring sufficient additive to match the range offered by the fuel tank. For the LF Series, this is sufficient for a range of up to 2,500 miles, so that drivers will not have to fill the AdBlue tank too often.

EEV (Enhanced Environmentally friendly Vehicle) engine

Especially for inner-city distribution, there is an EEV 160 hp version of the LF available in which low EEV emission values are achieved, by optimal combustion, without the need of a soot filter.



Integrated drive line technology

Manual or automatic

An economical engine is only the starting point for an efficient drive line. Gearbox and rear axle are equally important when it comes to efficiency and keeping cost per kilometre as low as possible. That is why DAF has been focussing for many years on integrated drive line technology. The drivelines in the LF Series are further proof of this philosophy.

The LF Series offers an extensive selection of gearboxes and rear axle ratios. There is a choice of refined, smooth shifting 'H' pattern five-, six- or nine-speed manual transmissions. Shifting through the gears with the short and direct gear lever is a joy, making the driver's life easier, even in heavy traffic.

Automated gear shifting

To further optimize comfort and efficiency, AS-Tronic six-speed gearboxes are available as an option on all LF types. This automated gearbox employs an electronic system to select the right gear for every situation, resulting in lower fuel consumption and enhanced driver comfort. Because the driver can fully concentrate on the traffic, an AS-Tronic gearbox can improve safety too. If the driver does decide to take control, the AS-Tronic can be shifted manually, using rocker switches, without

using a clutch. For special applications, such as fire engines or refuse collection vehicles, a fully automatic five-speed Allison transmission is available.

Reliable, economic rear axles

To cater for many applications, the LF Series has a range of DAF single reduction rear axles. These axles have earned an excellent reputation for long service life, excellent reliability, and above all, low internal resistance. This means less energy losses in the drive line resulting in better fuel consumption. The wide selection of rear axle ratios available, allows the selection of exactly the right driveline for each individual application. ASR anti-slip control that prevents spinning of the drive wheels, is available as an optional extra.

AS-Tronic automated gearboxes are available as an option for the LF.





The chassis lay out optimises the available space and is already prepared to accept a variety of superstructures to suit a wide range of applications.

Totally flat chassis for easy body mounting

Designed for high payloads

To satisfy as many distribution needs as possible, the LF is available in various wheelbases and axle configurations, including tractors and a three-axle rigid with steered trailing axle. The chassis layout and positioning of components has been optimized, to minimize vehicle weight and optimize the available space for auxiliary equipment. More payload and lower costs per kilometre were the design criteria for the chassis too.

The LF-chassis is made of high quality steel, resulting in an exceptionally strong but lightweight chassis for high payloads. It is completely flat, making it the ideal base for any superstructure. To make the bodybuilder's job as easy as possible, the main frame members are pre-drilled to ensure easy mounting of the body.

Best-in-class payload

Strong, but as light as possible for best-in-class payloads, a totally flat chassis to make the body builder's life easier, and great durability and reliability. These were the main design principles behind the development of the chassis of the DAF LF Series. The result: exceptionally high payloads, varying from 3 tonnes with a GVW of 6 tonnes on the lightest LF45, to 13 tonnes on the 18 tonnes version of the LF55. The LF55 with steered trailing axle even combines a payload of around 15.5 tonnes with maximum manoeuvrability. All LF's feature a considerable front axle load tolerance to prevent overloading in case of partial loads.

Brakes and suspension

Depending on the configuration, the LF is available with parabolic springs or electronically controlled air suspension. For applications requiring a short rear overhang, such as refuse collectors, asymmetric leaf springs are available. Ventilated disc brakes all round provide



The chassis is totally flat, making it easier for the body builder.

positive but progressive braking bringing safety and controllability to the LF, in combination with the exhaust brake which helps to reduce brake pad wear.

PTO programme

In view of the wide range of applications of vehicles in the DAF LF45 and LF55 class, there is also a demand for a PTO in this segment. For example for a fridge unit, tipper or crane drive unit. Again the LF provides tailor-made solutions with a wide range of PTO options.

Unbeatable driving characteristics

A joy to drive

Like every DAF, the LF Series too is characterized by superb driving properties and excellent manoeuvrability. A great deal of attention has been devoted to ideally match chassis design, steering, brakes and suspension. This, together with the high torque characteristics of the engines and comfortable cab design, makes the LF Series a joy to drive under all circumstances.

The spacious cabin with comfortable seating position, excellent visibility, ease of operation, comfortable suspension and tight turning circle for great manoeuvrability all form the basis for enjoying every mile in an LF. As do the PACCAR engines for great performance, the smooth ride and accurate steering behaviour for excellent road holding and power steering for minimum effort even at low manoeuvring speeds. Add to this a whole range of safety enhancing features, including the optional steering wheel airbag, and the ideal distribution truck is born: the DAF LF Series, offering maximum driving pleasure for the driver.

For the operator, the LF Euro 4 and Euro 5 vehicles offer a solid foundation for low cost of operation and high transport efficiency, combined with the highest standards of quality and reliability for optimum availability. And finally, the LF is designed for durability, resulting in higher resale values.







Committed to World Class

Right first time

DAF Trucks – A PACCAR Company – applies state-of-the-art technology to maintain the highest standards in development and manufacturing. Over the last few years, major investments have been made in all DAF factories. DAF trucks are built in world-class facilities by dedicated people, using high-quality materials and efficient processes.

For the production of the Euro 4 and Euro 5 models the production facilities at both Leyland and Eindhoven have seen considerable renewal programmes, making them amongst the most modern of their kind in the world. In the LF's assembly plant a sophisticated robotic chassis paint system, the first of its type in the world, ensures the highest efficiency and quality levels. DAF Trucks introduced World-Class Manufacturing standards: everything right first time, with no unnecessary loss of energy or materials and with the highest conceivable quality. As a result, world-class products are manufactured in world-class factories.

Information Technology

DAF Trucks and its dealers have Information technology systems that track a truck and its components throughout its entire life cycle – from design and production to aftermarket customer support. Engineering applies powerful three-dimensional CAD/CAM techniques that seamlessly interface with the production systems, ensuring employees receive

detailed on-line work instructions. The engineering data for each individual truck is centrally stored for guaranteed traceability, making it easy for dealers to check specifications and order parts – right down to the options fitted.

Product Development

The DAF Technical Centre offers comprehensive research, development and testing facilities, including an anechoic chamber for noise measurements and a modern engine laboratory. DAF also has an extensive proving ground for simulating road conditions so vehicle performance can be thoroughly tested. DAF Trucks delivers world-class vehicles, designed in world-class development facilities by a world-class development team.

EcoDesign and environmental policy

DAF has had an environmental policy in place for over 10 years, covering all its activities, products, services and locations – including dealers. Its environmental care system is ISO 14001 approved. DAF is committed to conducting its business in a responsible way. EcoDesign is the company's unique approach to environmentally responsible product design, and is concerned with ensuring that all of DAF's products comply with the strictest environmental guidelines, from first concept to end-of-life recycling.

DAF uses World-Class Manufacturing standards:

Right first time; no waste of energy and materials; highest quality standards.





DAF's one-stop-shop offers a total transport solution

With you all the way

Road transport is all about optimum efficiency, so DAF offers a total transport solution, designed to maximize earnings per kilometre. It is supported by a professional organization and dealer network that helps customers choose the right vehicle, finance it, maintain it in perfect condition, and keep it running at all times.

DAF Trucks not only makes quality vehicles, but also has a first-class back-up organization with around a 1,000 independent dealers in Europe. They provide support ranging from financial services to repair & maintenance contracts. Parts for trucks and trailers are always available, supplied to workshops by PACCAR Parts Distribution Centres in the Netherlands, the United Kingdom and Spain. Every week, over 3,000 shipments are made to dealers and customers across Europe and beyond – often within 24 hours.

Tailored Repair & Maintenance services for improved profitability

By offering a fixed price per kilometre for repair & maintenance, DAF MultiSupport ensures a perfectly maintained fleet without unexpected high costs. Customers can choose the level of services, with options for trailer and body cover. Benefits include increased transparency in

operational costs and reduced administration, enabling fleet operators to focus more on the transport business. DAF MultiSupport helps maximize the return on investment in your vehicle.

Tailor-made financial services

PACCAR Financial has 50 years experience in the transport industry and understands today's business needs. Services include financing the total truck combination, R&M contracts and insurance. PACCAR Financial is available at all DAF dealer locations, providing one-stop access for trucks and financial help – including solutions for national and pan-European operators.





Always on stand-by throughout Europe

If something unexpected should ever happen, one telephone call to DAF's International Truck Service (ITS) gets the truck rolling again with minimum delay. Often copied but never equalled, ITS is on stand-by day and night, 365 days a year. Experienced employees mobilize the DAF service organisation, handling language and financial issues to ensure that a stranded truck is back on the road with minimum delay.

***At DAF, we understand better than anyone else
that a truck has to keep moving***

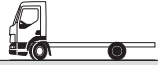

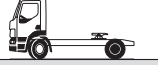
The LF Series axle configuration overview

LF45, models G6-G12, 17,5" wheels			
4x2	FA		GVW 6-12 ton GCW up to 22 ton
LF55, models G12- G15, 19,5" wheels			
4x2	FA		GVW 12-15 ton GCW up to 28 ton
6x2	FAN		GVW 21 ton
4x2	FT		GCW up to 28 ton
LF55, models G16-G18, 22,5" wheels			
4x2	FA		GVW 16-19 ton GCW up to 32 ton



The LF engine overview

Engine type	Maximum power output	Maximum torque	Emission level
PACCAR FR engine: 4.5 litre, four-cylinder			
PACCAR FR103	103 kW/140 hp @ 1,900-2,500 rpm	550 Nm @ 1,200-1,700 rpm	Euro 4
PACCAR FR118	118 kW/160 hp @ 1,900-2,500 rpm	600 Nm @ 1,200-1,800 rpm	Euro 4 / 5 / EEV
PACCAR FR136	136 kW/185 hp @ 2,000-2,500 rpm	700 Nm @ 1,200-1,800 rpm	Euro 4
PACCAR GR engine: 6.7 litre, six-cylinder			
PACCAR GR165	165 kW/220 hp @ 1,900-2,500 rpm	850 Nm @ 1,200-1,700 rpm	Euro 4 / 5
PACCAR GR184	184 kW/250 hp @ 1,900-2,500 rpm	950 Nm @ 1,200-1,700 rpm	Euro 4 / 5
PACCAR GR210	210 kW/285 hp @ 2,100-2,500 rpm	1,020 Nm @ 1,200-1,800 rpm	Euro 4

PACCAR FR engines

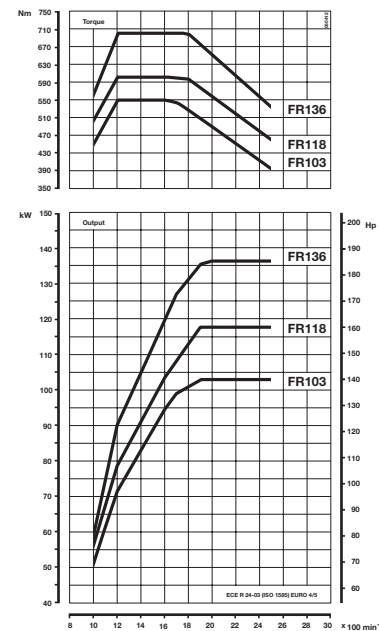

PACCAR GR engines

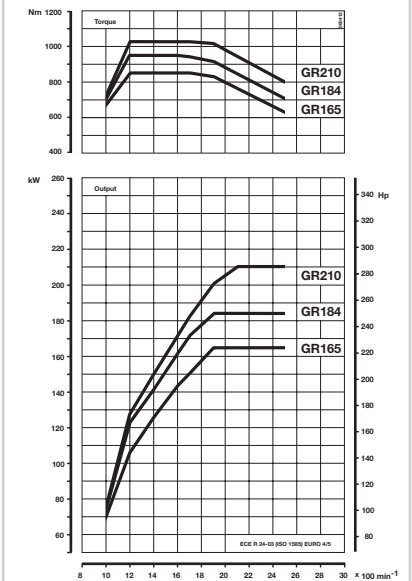

DAF LF45 Day Cab

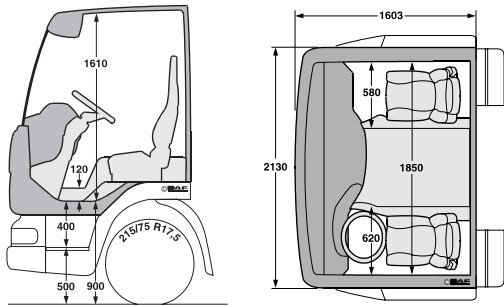

DAF LF55 Day Cab

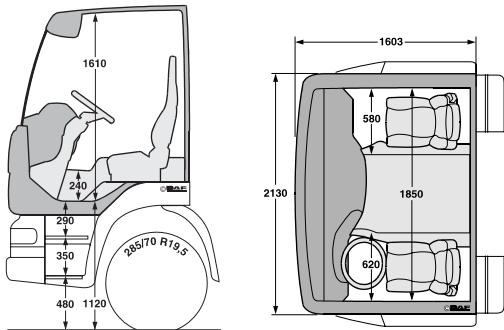

DAF LF55 Sleeper Cab

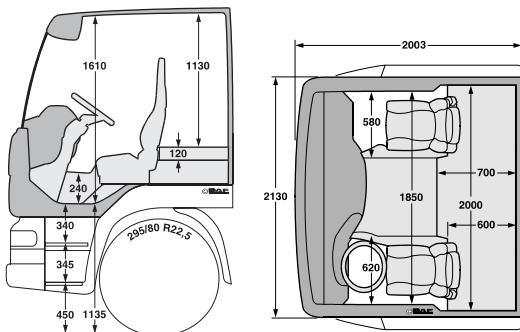



The most modern product range on the market

A truck for every need

Every transport application has unique requirements, so every DAF vehicle is unique, built to order from a range of cab, chassis, driveline and axle configurations. Three vehicle concepts – the XF, CF and LF – one quality standard: the best. When ordering, the DAF sales specialist guides customers through the selection process using state-of-the-art software, ensuring the specifications exactly match the application. Whatever the challenge, there's a DAF to meet it.



With a balanced selection of cabs, engines, drive lines and axles, there's a DAF truck that precisely matches your needs, whatever the application.



No rights can be derived from this publication.
DAF Trucks N.V. reserves the right to change
product specifications without prior notice.
Products and services comply with the European
Directives effective at the time of sale but may
vary depending on the country in which you are located.
For the most recent information,
contact your authorized DAF dealer.

Mirrors, bumpers and headlamp panel are not available ex-factory in body colour.

DAF Trucks N.V.
Hugo van der Goeslaan 1
P.O. Box 90065
5600 PT Eindhoven
The Netherlands
Tel: +31 (0) 40 21 49 111
Fax: +31 (0) 40 21 44 325
www.daf.com

DW 14193502/HQ-GB: 1007

driven by quality



Environmental
Management
System

DAF
A PACCAR COMPANY

